

Ax550i – advanced heavy duty printer

The **Ax550i** heavy-duty continuous ink jet (CIJ) printer is designed to deliver high quality codes even in the harshest environments onto virtually any surface and product.

The **Ax550i** is compatible with Industry 4.0 standards. Connecting to **Domino Cloud** enables remote diagnostics and 24/7 visibility of your printers' performance. The touchscreen user interface provides a class-leading user experience.

Domino's service-free ink system with **i-Pulse** printhead technology utilising Domino-developed inks provides clear, readable text, graphics and barcodes while ensuring regulatory compliance.



Maximised production uptime

- ◆ The stackable marine grade 316 stainless steel cabinet is dust-tight and with a sealed IP66 electronics enclosure made to withstand washdowns, high-pressure water blasting, or chemicals.
- ◆ The **Ax550i** is service-free; only the **iTechx** module (ITM) needs to be replaced once annually, which is a less-than-ten-minutes operator task.
- ◆ Coding automation and integration into your ERP and MES business systems are supported. Connect to **Domino Cloud** to benefit from remote printer performance overviews and diagnostics.



i-Pulse printhead technology

- ◆ Printheads start up first time even after extended shutdowns thanks to Domino's unique nozzle-sealing technology.
- ◆ Best readability and reliability at faster speed in a higher 9-drop resolution (versus traditional 7 drops) plus up to 24% less ink usage result from optimised ink drop formation.
- ◆ Printheads for every application: 90-degree angled and rotatable printheads for narrow products; highly durable, hygienic round steel variants for heavy duty environments; 40µ and 50µ printheads for small, precise codes and the Duo printhead for doubled speed.

Codes to create a lasting impression

- ◆ Domino supplies a range of inks manufactured to GMP (Good Manufacturing Practice) which are compliant with leading global legislation for food packaging.
- ◆ Our inks offer lasting adhesion, lightfastness and high contrast even on difficult substrates (e.g. polyolefins) and after harsh post-print processes.
- ◆ Environmental-friendly options, reduced ink consumption, optimised packaging and fully-depleting cartridges reduce waste and ecological footprint.

www.domino-printing.com



A complete solution



Our services are designed to provide operational insight so you can eliminate downtime and maximise production efficiency

Operational support

An outstanding level of care, wherever you are. Our **SafeGuard** packages provide high-quality, on-site assistance and AR-enabled remote guidance from our engineers. **SafeGuard** helps to ensure we can be with you when you need us most.

Automatic code inspection

Ensure every code that leaves your factory is present and correct, and free up operator time. With the R-Series, Domino's range of vision control systems, you can automate your code inspection to validate code presence, placement, and readability.

Control software

Minimise errors using Domino's **QuickDesign** software. Control your product codes from a central location and streamline product changeovers. **QuickDesign** uses standard communication protocols and can be integrated into existing ERP systems.

Smart production

Gain operational insight by connecting your printer to **Domino Cloud**. Obtain production analytics dashboards and receive system error alerts. **Domino Cloud** provides you with the information you need to run your operations more efficiently.

Technical specification Ax550i

Printing Specification				
Printhead nozzles	40µm	50µm	60µm	75µm
Speed – 1 line, 5 dot characters(m/s)*	5.3	5.9	7.1	6.8
Dot size(mm)**	0.23	0.26	0.31	0.4
Print heights (single print head)	Up to 32 dots/20mm			
Print heights (Duo)	Up to 64 dots/40mm			
Supported code formats	full unicode support text, graphics, 1-D, 2-D codes			
Ownership Specification				
User interface	7" and 10.4" touch screen options			
Conduit length	3m & 6m options			
Printhead type	Straight, H90, V90, RS and Duo			
Software	QuickStep 3			
Comms ports	Cabinet USB port (x1); Ethernet RJ45 port (x1)			
Printer status monitoring	4 stage beacon output (x1); 3 stage alarm output (x1)			
Cartridge replacement (Ink and make-up)	Auto recognition;			
Servicing – ITM replacement	20 second operator task; no line stop required			
Service interval***	Sub 10 minute operator task, line stop required			
Material	Typically every 12 months			
	316 stainless steel, IP55 cabinet; IP66 electronics enclosure			
Consumables****				
Inks	Wide range of black and coloured inks including options for food packaging, eggshells, colour change, industrial, UV-fluorescent			
Ink cartridge volume	825ml			
Make-up cartridge volume	1200ml			
Optional Hardware Packs*****				
Extended comms pack	Cabinet USB port (x1); control port (x1); touchscreen / Ethernet port (x1)			
RS232 pack	RS232 port (x1)			
GPIO pack	I/O – 4 inputs/4 outputs (x1)			
Extended I/O pack	I/O - 12 inputs / 6 outputs (x1)			
Optional Performance Packs				
Operator assistance pack	Label templates; barcode scanning for labels and data entry; local security manager			
Green pack	Up to 20% reduction in make-up emissions; configurable printhead and ink-system stand down for reduced power usage			
Continuous printing pack	Dedicated user screens for faster changes during production; easier label creation; high speed print formats (ST&HS rasters)			
Advanced security pack	Full security manager to secure user interface and provide customisable permissions based on individual user logins			

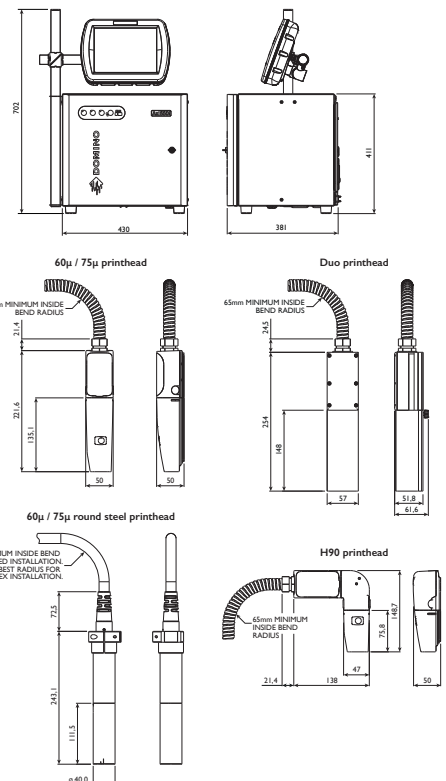

*Speed quoted at the following characters per inch ---- 60µm = 10 characters. **Dots size may vary depending on substrate type. ***Service interval is ink type dependent. ****This product has a Quality Management System that means that it will only work with Domino circuitry, and it uses dynamic security measures to block non-Domino circuitry from being used. From time to time updates to the circuitry will be issued by Domino to maintain the effectiveness of the Quality Management System. *****May vary per sales region.

Logos and 2D Codes



Multi Language and Mixed Fonts

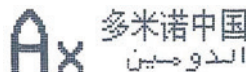

TALK TO AN EXPERT

Contact details: enquiries@domino-uk.com
Telephone: +44 1954 782 056
Website: www.domino-printing.com